

CAD FILE:

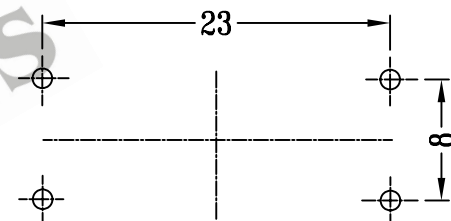

P.C.B LAYOUT

注:带"\*"表示关键尺寸(8个)

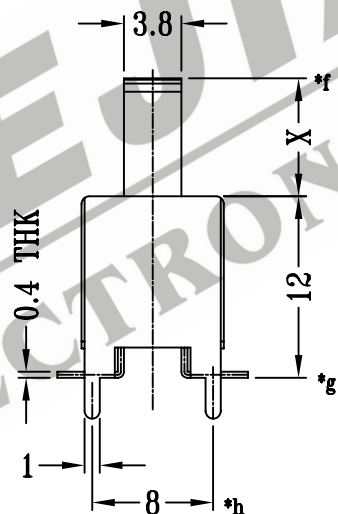
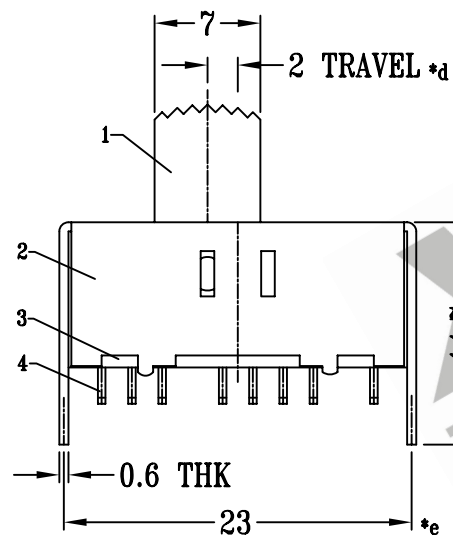
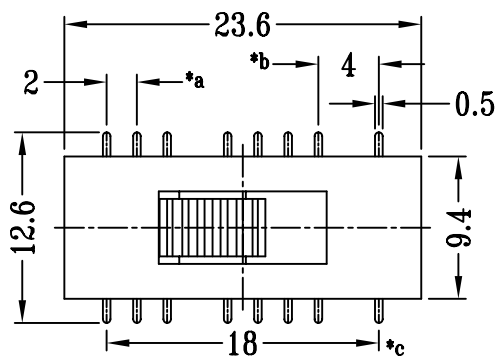
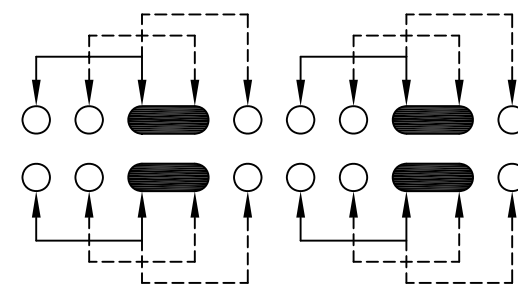

SCHEMATIC (SHORTING)

NO.	PARTS	MATERIALS	Q'TY	FINISH	TOLERANCE UNLESS SPECIFIED	SHENZHEN XIEJIA ELECTRONICS CO.,LTD.					
8						ISSUE		DATE		DESCRIPTIONS OF REVISION	APPD.
7	STEEL BALL	STEEL	2	NATURAL	WITHIN: 1.5±0.1mm OVER: 1.5±0.2mm	TITLE: VERTICAL SLIDE SWITCH		UNIT: mm	DRWG NO.:XJ-DR-SS43D13-00		
6	SPRING	STEEL WIRE	1	TEMPER		MODEL: SS-43D13		SCALE: 2:1	DWN.	ZHOUYU	2005-3-18
5	CONTACT CLIP	PBS STRIP	4	Ag PLATED					CHK'D	FANGYING	2005-3-18
4	TERMINAL	BRASS STRIP	16	Ag PLATED OVER Ni PLATED		ALL MATERIALS MUST BE COMPLIANT TO ROHS			APPD.	KANGXINAN	2005-3-18
3	BASE	PHENOLIC RESIN	1	NATURAL							
2	FRAME	STEEL STRIP	1	Ni PLATED							
1	KNOB	POM	1	BLACK							